

CLIFF

COMBI-JACK

COMBINED JACK / XLR IN ONE BODY



The hybrid Jack / XLR offers space saving opportunities in designs where jacks and XLR may be not used simultaneously, or where space available is inadequate to use separate components.

FEATURES:

- Panel mounting by self tap screws.
- XLR with retention spring.
- Optional push latch for all models.
- Optional grounding switch on XLR.
- Optional mono unswitched jack.
- Optional stereo unswitched jack.
- Optional stereo switched jack.
- Optional horizontal PCB mounting.
- Optional vertical PCB mounting.
- Optional solder tag wiring.
- UL94 Approved materials.

SPECIFICATION - XLR

Insertion force : 0.3~4.0 kgf

Contact Resistance:

Initial: Max 30mΩ

SPECIFICATION - JACK SOCKET

Insertion force : 0.3~3.0 kgf

Contact Resistance:

Initial: Max 30mΩ

Cliff Electronic Components, Ltd.

76 Holmethorpe Avenue, Holmethorpe Ind. Est.

Redhill, Surrey RH1 2PF. England

Tel: +44 (0) 1737 771375

Fax: +44 (0) 1737 766012

Email: sales@cliffuk.co.uk



Visit us online at:



www.cliffuk.co.uk

GENERAL DIMENSIONS
90° PCB WITH LATCH

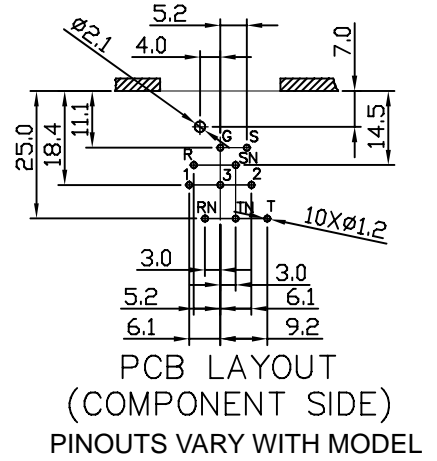
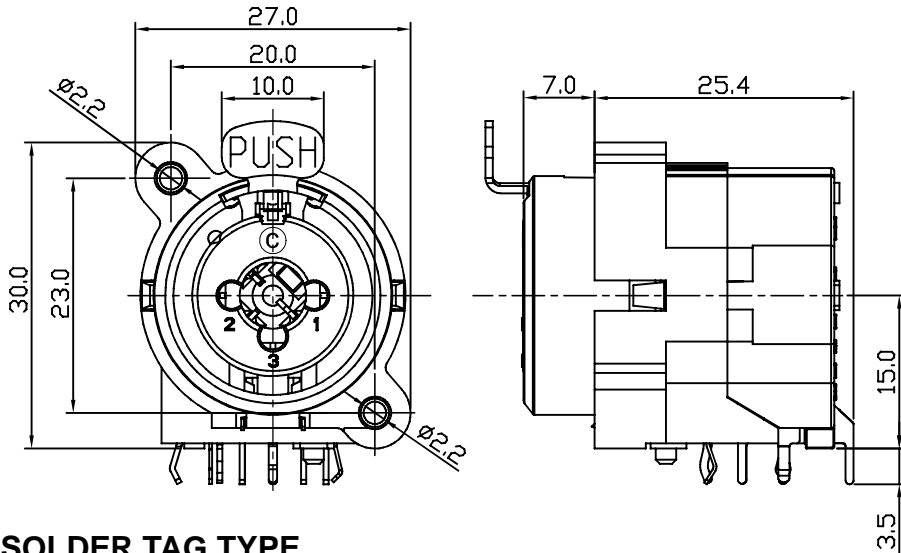

SOLDER TAG TYPE

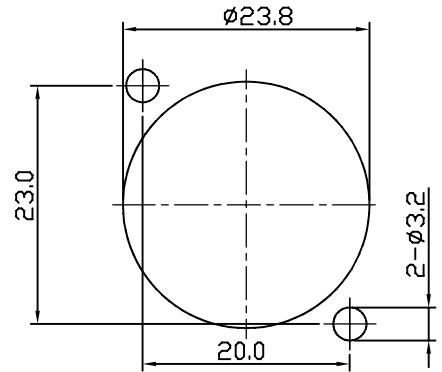
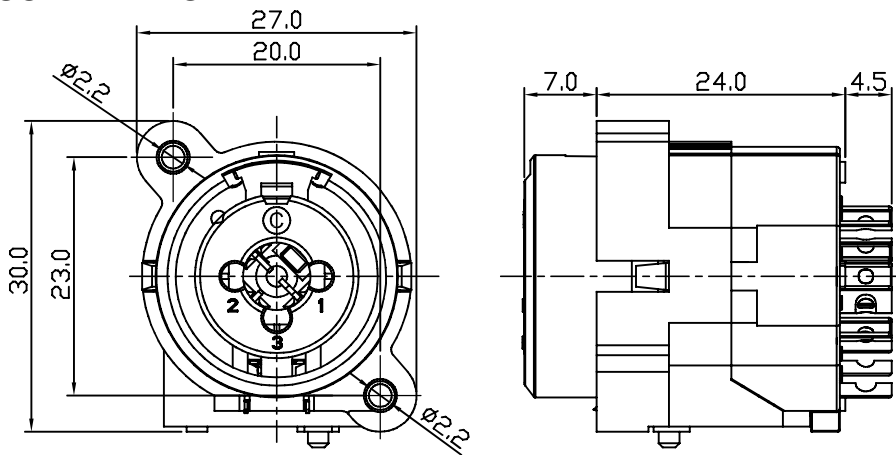

VERTICAL PCB WITH LATCH

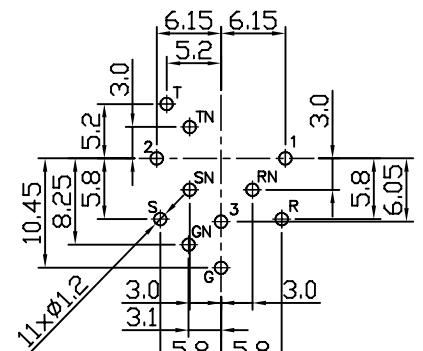
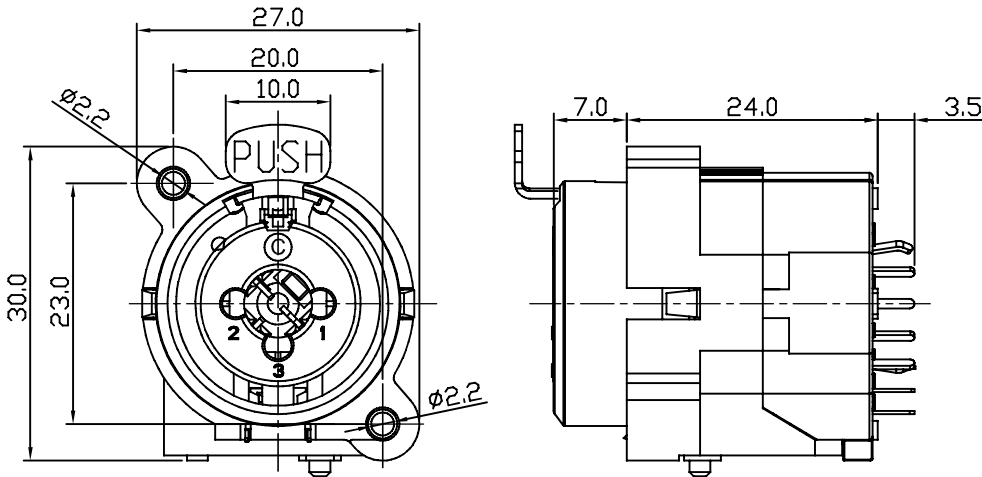

VARIANTS	STEREO JACK UNSCREENED	STEREO JACK SCREENED
90° PCB		
WITHOUT XLR GROUND SCREEN	FC2410	FC2420
WITH XLR GROUND SCREEN		FC2430
VERTICAL PCB		
WITHOUT XLR GROUND SCREEN	FC2440	FC2450
WITH XLR GROUND SCREEN		FC2460
SOLDER TAGS		
WITHOUT XLR GROUND SCREEN		FC2480
WITH XLR GROUND SCREEN		FC2490

For Push latch version - Add L to P/No. e.g. FC2410L

